

Rotary Screw Compressors DSD/DSDX Series

With the world-renowned SIGMA PROFILE 

Free air delivery from 12.68 to 30.20 m³/min – Pressure 5.5 to 15 bar



What do you expect from a compressor with variable frequency drive and refrigeration dryer?

As a user, you expect maximum efficiency, reliability and consistent air quality from your compressed air system.

That may sound simple, but these advantages are influenced by many different factors:

Energy costs, for example, taken over the lifetime of a compressor, add up to a multiple of investment costs.

Efficient energy consumption therefore plays a vital role in every compressed air system, as does reliability.

It is also important that the compressed air system delivers condensate-free compressed air in the correct volume and quality for the specific application. This not only increases system reliability, but also significantly reduces maintenance costs for the air distribution network, compressed air tools, pneumatic control systems and any other equipment that uses compressed air.

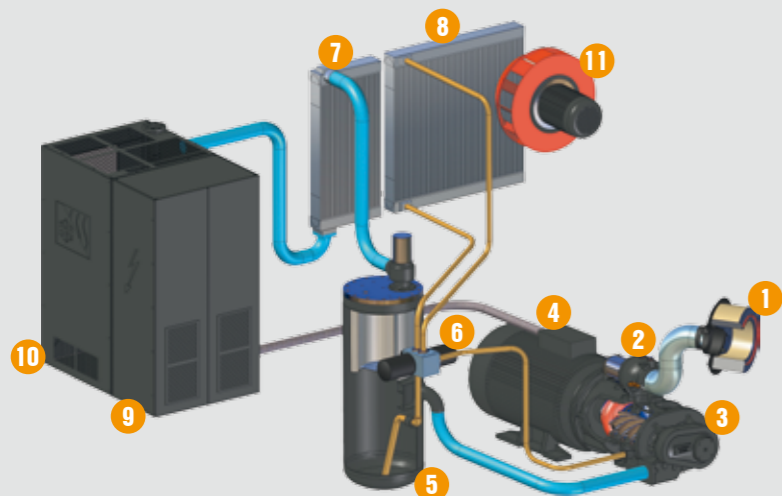
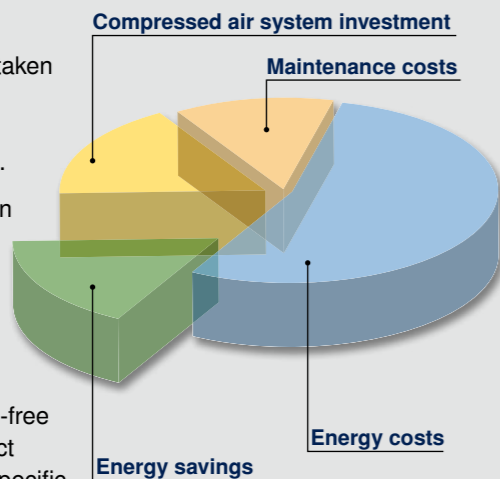

DSD/DSDX

**KAESER's solution:
Versatile modular design**

Available with optional SFC variable frequency drive, KAESER's highly efficient DSD and DSDX rotary screw compressors are not only simple to install but also offer outstanding versatility and performance. Furthermore, DSD series compressors can be equipped with a refrigeration dryer.



- 1 Intake filter
- 2 Inlet valve
- 3 SIGMA PROFILE airend
- 4 Drive motor
- 5 Fluid separator tank
- 6 Fluid filter
- 7 Compressed air aftercooler
- 8 Fluid cooler
- 9 Frequency converter (Optional)
- 10 Refrigeration dryer (Optional)
- 11 Fan

Tailored, modular design for maximum efficiency



DSD/DSDX – Efficiency as standard

DSD and DSDX series compressors with energy-saving 1:1 drive form the basis for KAESER's versatile modular concept. They are particularly efficient, durable and reliable as each is equipped a generously-sized low speed airend featuring SIGMA PROFILE rotors.



T – With refrigeration dryer

DSD compressors are available with an integrated refrigeration dryer module. The compressor and dryer are housed in separate cabinets with individual cooling air apertures and cooling systems to ensure maximum operational reliability.



SFC – Sigma Frequency Control

The SIGMA FREQUENCY CONTROL (SFC) variable frequency drive module is available for DSD and DSDX compressor systems. The SFC module and the compressor are seamlessly integrated into a compact, hard-wired unit that delivers maximum performance, yet requires minimal floor space. Each package is delivered tested and ready for operation.

Maximum flexibility

KAESER's versatile range of modular T SFC packages ensures that a model is available to suit every compressed air need. The refrigeration dryer module (C) transforms a standard rotary screw compressor into a compact compressed air system that delivers quality, dried-air in accordance with the highest standards. With the addition of the SFC module (B), the compressor speed can be automatically adjusted to meet varying air demand. All possible combinations of these three modules are available.

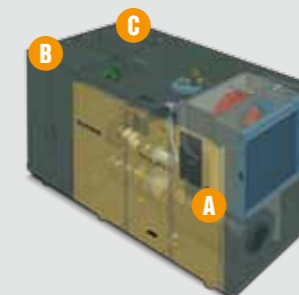

- A = Rotary screw compressor DSD Series
- B = SFC
- C = Refrigeration dryer (T)

DSD T – With compact refrigeration dryer

The innovative DSD T series

Combining unrivalled reliability with exceptional efficiency, KAESER's new DSD T rotary screw compressor systems provide space-saving, energy efficient compressed air generation and treatment in a single compressor package.

The addition of the integrated refrigeration dryer module transforms the high performance DSD compressor unit into a complete air supply system, which is able to operate in ambient conditions of up to +45°C.



Dependable centrifugal separator

A centrifugal separator with an electronically controlled ECO DRAIN is installed between the compressor and the dryer. This ensures safe and efficient initial separation and drainage of the condensate even under conditions of high ambient temperature and humidity.



Refrigeration dryer with ECO DRAIN

The refrigeration dryer also features an ECO DRAIN. The advanced level-controlled condensate drain eliminates the compressed air losses associated with solenoid valve control. This both saves energy and considerably enhances the reliability of the compressed air supply.

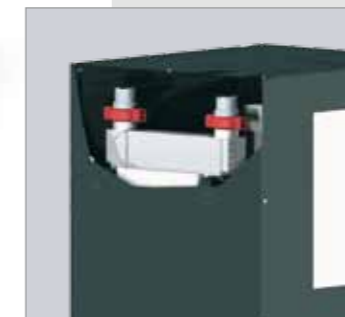

Aluminium plate heat exchanger

The aluminium plate heat exchanger in the refrigeration dryer is both corrosion- and contamination-resistant. Even with fluctuating airflow, the heat exchanger reliably separates the accumulating condensate from the air. The dryer's components and piping are designed to provide exceptional operational safety and reliability.

Turnkey operation

Contained in its own separate cabinet there is more than sufficient space to allow all the components in the dryer to be generously sized yet easily accessible for maintenance. This design also prevents exposure of the refrigeration dryer to any heat from the compressor package. Individual cooling air apertures and intelligent design ensure outstanding reliability in ambient temperatures of up to +45°C, which significantly increases compressed air availability. The bearings in the drive and fan motors can be externally lubricated.



SIGMA CONTROL

The SIGMA CONTROL compressor controller constantly monitors the compressor, refrigeration dryer and condensate drains. If required, signals from the dryer can be defined as alarms and forwarded to a centralised control centre.

DSD/DSDX SFC – Ultimate efficiency



The advanced DSD/DSDX SFC series

Every KAESER rotary screw compressor is equipped with a large, efficient airend featuring high performance SIGMA PROFILE rotors. The airends in DSD/DSDX units are powered by a direct drive system that eliminates the transmission losses associated with gear drive systems, enabling these compressors to provide significant energy savings. Considerable savings can also be achieved with the addition of a SIGMA FREQUENCY CONTROL (SFC) module.

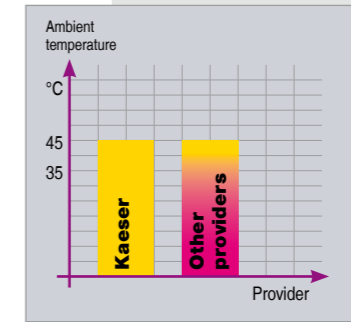

Perfect performance – even with high ambient temperatures

The generously-sized SFC module with its efficiently-cooled control cabinet allows trouble-free operation in ambient temperatures up to +45 °C.

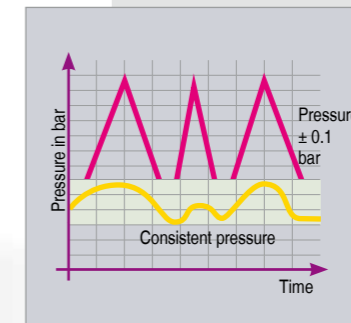

Consistent pressure

Air delivery from a DSD or DSDX SFC compressor can be matched to actual air demand, according to required system pressure, by continuously adjusting drive motor speed (and therefore the airend) within its specified control range. Depending on the buffer capacity of the downstream air network, it is therefore possible to precisely maintain working pressure to within ± 0.1 bar and, as a result, to reduce maximum system pressure. This can lead to significant savings, as each 1 bar reduction in pressure amounts to a 7 percent reduction in energy consumption.

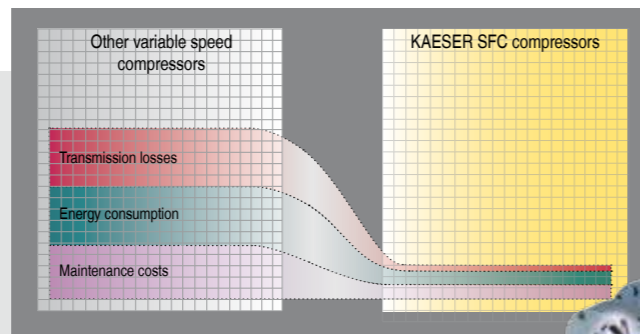

Outstanding performance

DSD/ DSDX SFC compressor packages are highly efficient direct drive units featuring variable speed control. With high-efficiency performance throughout the entire control range, large, low speed airends featuring the energy saving SIGMA PROFILE have significant advantages over smaller, high speed airends.

All packages are designed to operate at full load, 7 days a week, yet require no additional maintenance. **Direct drive** reduces the number of components needed in comparison with gear drive and eliminates the associated transmission losses. This significantly increases reliability and service life; sound levels are also considerably lower. The benefits speak for themselves: efficient power transmission, optimal power consumption and reduced servicing / downtime costs.

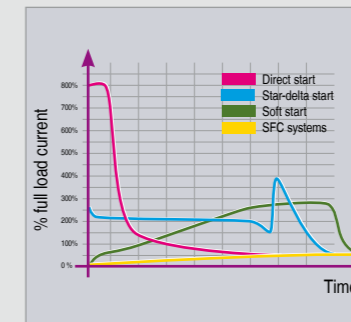

Soft start with no current spikes

Soft start allows a gradual increase in drive motor current from zero to full load, enabling almost unlimited motor switching frequency i.e. the number of times the motor can be switched on within a defined time period without overheating. Current spikes that can potentially cause damage to power systems and equipment are reliably eliminated without the need for additional expensive electronics. In addition, the continuously variable acceleration and deceleration of moving parts reduces dynamic loading.

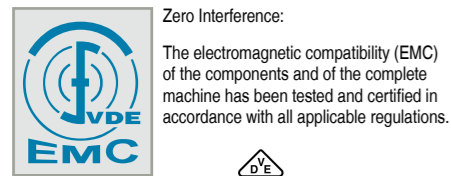

DSD and DSDX – Eight decisive advantages



1 SIGMA PROFILE air end

A specific drive power can be used to turn a smaller air end at high speed or a larger air end at slow speed. Larger, low speed air ends are more efficient, delivering more compressed air for the same drive power. That is why KAESER developed air ends especially for the DSD and DSDX series that precisely match the individual drive power and motor speed of each machine in the range. The slightly higher investment cost of the larger air end is quickly recovered by the energy saved during operation.



2 Energy-saving 1:1 drive

The advantages of Kaeser's 1:1 drive system are not just limited to the elimination of transmission losses. The motor and air end are joined by the coupling and its housing to form a compact and durable unit that, apart from greasing of the motor bearings, requires no regular maintenance. Should the coupling ever need to be replaced it takes just a few minutes without any disassembly of the unit, as the opening in the coupling housing is more than large enough to replace the two coupling sections.

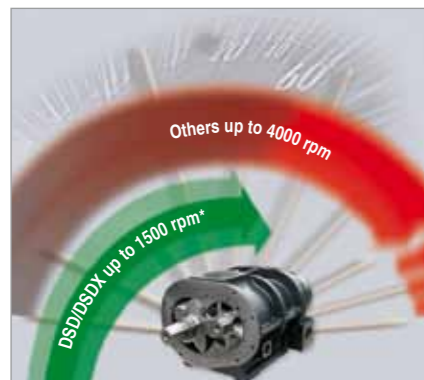

3 Low speed operation

Each DSD / DSDX compressor has exactly the same mechanical components as those used in KAESER's standard fixed speed compressors. This not only ensures unrivalled reliability and compressed air availability, but also guarantees optimum energy efficiency. The most efficient method of producing compressed air is by using large, low speed air ends – air ends in DSD/ DSDX SFC compressors have a typical maximum rotation speed of approx. 2000 rpm. Further advantages include long service life and reduced maintenance requirement. The use of standardised drive motors also contributes to long-term compressed air availability.

* SFC up to 2000 rpm



4 SIGMA CONTROL

Based on robust PC architecture, the SIGMA Control offers the possibility of Dual, Quadro, Vario and Continuous control. Clearly marked navigation and input keys on the user interface are used to move around within the menu options of the four line alpha-numeric display. This powerful compressor controller can also display information in any 1 of 30 selectable languages at just the press of a button. The SIGMA CONTROL automatically controls and monitors the compressor package. The Profibus interface enables exchange of data and operational parameters allowing the SIGMA Control to communicate with other air management systems such as the Sigma Air Manager. Interfaces are provided as standard for connection of a modem, a second compressor in base-load sequencing mode and for connection to data networks (Profibus DP).

5 Highly efficient condensate separator (with DSD T)

The separator tank in the refrigeration dryer is made of aluminium and is therefore completely corrosion resistant. The compact separator is integrated within the refrigeration dryer's heat exchanger package and deflector plates ensure reliable condensate separation. Separation performance remains almost constant – even with fluctuating airflow – reliably maintaining the required pressure dew point. Solid particles are also washed out and eliminated together with the condensate.

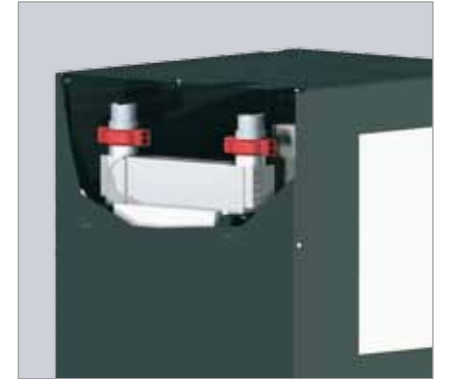

6 SFC module from Siemens (with DSD and DSDX)

Siemens frequency converters are used exclusively in KAESER's speed controlled compressors for several reasons: Siemens manufactures the industrial PC-based SIGMA CONTROL compressor controller, which enables seamless communication with the SFC control cabinet. Furthermore, the worldwide presence of Siemens ensures dependable service. The SFC control cabinet and SIGMA CONTROL are Class A1 tested and certified as per electromagnetic compatibility regulation EN 55011, both as individual components and as an integrated system.



7 Flexible pressure adjustment

The wide range of 1:1 drive air ends available makes it possible to select the one that works most efficiently within the pressure and performance range required. This ensures that every DSD and DSDX SFC compressor operates with the most efficient pressure-frequency profile. Furthermore, the SIGMA CONTROL compressor controller is equipped with a pressure-to-frequency profile that guarantees maximum flexibility for air delivery and pressure whilst providing best possible efficiency.

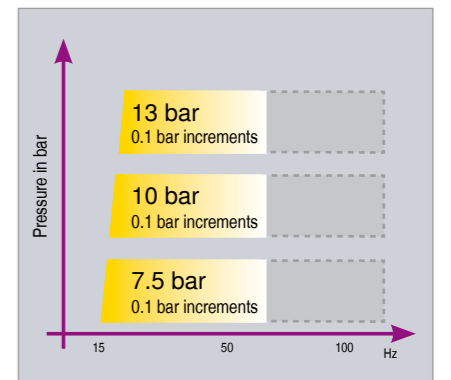

8 Specific power is the key

Large, low speed air ends are more efficient than small high speed air ends because they supply more air for the same drive power. This is not just the case at full load, but also applies throughout the entire control range, which is particularly important for variable speed machines. The specific energy requirement of 6.2 kW per m³/min for a KAESER SFC compressor operating at 7.5 bar can be considered as an excellent indication of the machine's efficiency. Variable frequency controlled compressors are only truly efficient if they have low energy consumption throughout their entire control range.



Equipment

Complete unit

Ready for operation, fully automatic, super silenced, vibration damped, all panels powder coated.

Sound insulation

Panels lined with laminated mineral wool; maximum 72 dB(A) to PN8NTC 2.3 at one metre distance, free-field measurement.

Vibration damping

Double insulated anti-vibration mountings using rubber bonded metal elements.

Airend

Genuine KAESER rotary screw, single-stage, fluid-injected airend with SIGMA PROFILE rotors.

Drive

Direct, high-flex coupling, without gearing.

Electric motor

Premium efficiency electric motor of quality German manufacture to IP 55, ISO F, for additional reserve.

Connection from motor to airend

Airend with integral coupling bell.

Electrical components

Control cabinet to IP 54, control transformer, switch cabinet for Siemens Masterdrive frequency converter (for SFC version), floating contacts for ventilation control.

Cooling

Air-cooled; separate aluminium cooler for compressed air and fluid; radial fan driven by its own motor (externally lubricated).

SIGMA CONTROL

Interfaces for data communication comprising: RS 232 for Modem, RS 485 for a slave compressor in base-load sequencing mode (not with SFC versions) and a Profibus (DP) interface for data networks. Prepared for Teleservice.



Professional planning

Compressed air supply system with separate components

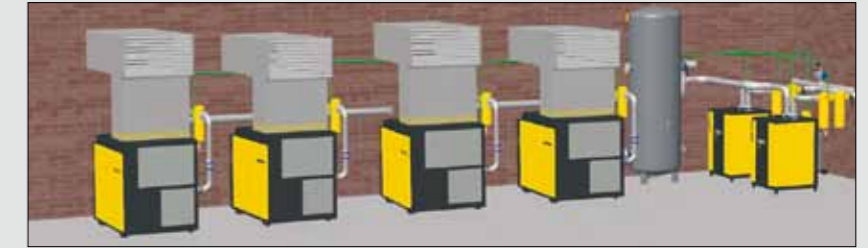

KESS (KAESER's Energy Saving System) provides comprehensive analysis of your compressed air usage, enabling KAESER's experts to plan and design a system that is specially tailored to meet all of your compressed air needs.

Typically ensuring a 95-98 % load capacity, KAESER compressed air systems provide exceptional efficiency and produce application-specific quality compressed air at lowest possible cost. Use this expertise to your advantage and let KAESER design your compressed air system.

Technical Specifications – DSD / DSDX

Standard version

Rated motor power kW	Model	Working pressure bar	FAD *) Complete package at working pressure m³/min	Max.-operating pressure bar	Dimensions W x D x H mm	Sound pressure level **) dB(A)	Weight kg
75	DSD 142	7.5	13.62	9	2350 x 1730 x 2040	68	2700
90	DSD 172	7.5 10	16.12 13.20	8.5 12	2350 x 1730 x 2040	69	2850
110	DSD 202	7.5 10 13	20.46 15.52 12.68	8.5 12 15	2350 x 1730 x 2040	70	3200
132	DSD 238	7.5 10 13	23.80 19.92 14.80	8.5 12 15	2350 x 1730 x 2040	71 79***)	3400
132	DSDX 243	7.5 10 13	24.10 20.12 14.90	8.5 12 15	2600 x 1980 x 2040	70 78***)	3650
160	DSDX 302	7.5 10 13	30.20 23.50 19.52	8.5 12 15	2600 x 1980 x 2040	71 78***)	4100

T – Version with integrated refrigeration dryer (Refrigerant R 134a)

Rated motor power kW	Model	Working pressure bar	FAD *) Complete package at working pressure m³/min	Max.-operating pressure bar	Dryer power consumption kW	Dimensions W x D x H mm	Sound pressure level **) dB(A)	Weight kg
75	DSD 142 T	7.5	13.62	9	2.1	3310 x 1730 x 2040	68	3100
90	DSD 172 T	7.5 10	16.12 13.20	8.5 12	2.1	3310 x 1730 x 2040	69	3250
110	DSD 202 T	7.5 10 13	20.46 15.52 12.68	8.5 12 15	2.35	3310 x 1730 x 2040	70	3650
132	DSD 238 T	7.5 10 13	23.80 19.92 14.80	8.5 12 15	2.35	3310 x 1730 x 2040	71 79***)	3850

SFC - Version with variable speed drive

Rated motor power kW	Model	Working pressure bar	FAD *) Complete package at working pressure m³/min	Max.-operating pressure bar	Dimensions W x D x H mm	Sound pressure level **) dB(A)	Weight kg
75	DSD 142 SFC	7.5	3.6 - 14.80	9	2905 x 1730 x 2040	69	3100
90	DSD 172 SFC	7.5 10	3.6 - 16.33 3.55 - 14.2	10 10	2905 x 1730 x 2040	70	3230
110	DSD 202 SFC	7.5 10 13	4.25 - 20.30 4.00 - 17.30 3.25 - 14.95	10 10 15	2905 x 1730 x 2040	71	3730
132	DSD 238 SFC	7.5 10 13	5.93 - 22.50 5.80 - 20.00 3.56 - 16.00	10 10 15	2905 x 1730 x 2040	72 79***)	3870
132	DSDX 243 SFC	7.5 10 13	6.62 - 26.90 5.60 - 23.73 3.56 - 19.00	8.5 12 15	3155 x 1945 x 2040	71 78***)	4150
160	DSDX 302 SFC	7.5 10 13	6.62 - 30.60 5.60 - 26.70 3.56 - 21.10	8.5 12 15	3155 x 1945 x 2040	72 78***)	4600

T SFC - Version with variable speed drive and integrated refrigeration dryer

Rated motor power kW	Model	Working pressure bar	FAD *) Complete package at working pressure m³/min	Max.-operating pressure bar	Dryer power consumption kW	Dimensions W x D x H mm	Sound pressure level **) dB(A)	Weight kg
75	DSD 142 T SFC	7.5	3.60 - 14.80	9	2.1	3310 x 1730 x 2040	69	3400
90	DSD 172 T SFC	7.5 10	3.60 - 16.33 3.55 - 14.20	10 10	2.1	3310 x 1730 x 2040	70	3530
110	DSD 202 T SFC	7.5 10 13	4.25 - 20.30 4.00 - 17.30 3.25 - 14.95	10 10 15	2.35	3310 x 1730 x 2040	71	4080
132	DSD 238 T SFC	7.5 10 13	5.93 - 22.50 6.60 - 20.00 3.56 - 16.00	10 10 15	2.35	3310 x 1730 x 2040	72 79***)	4220

Dimensions

Standard DSD version

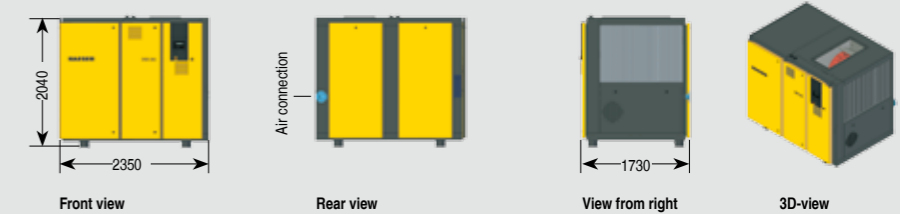

DSD T SFC version

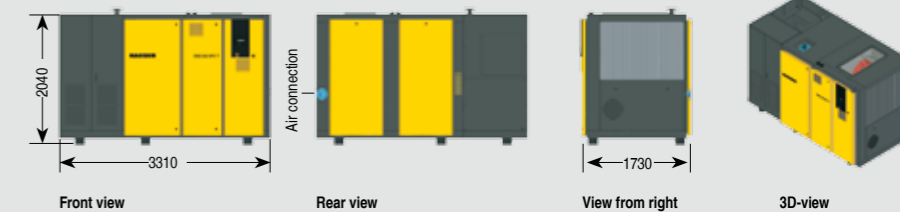

DSDX

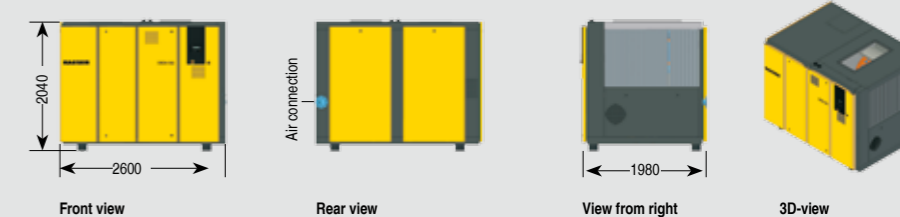

DSDX SFC

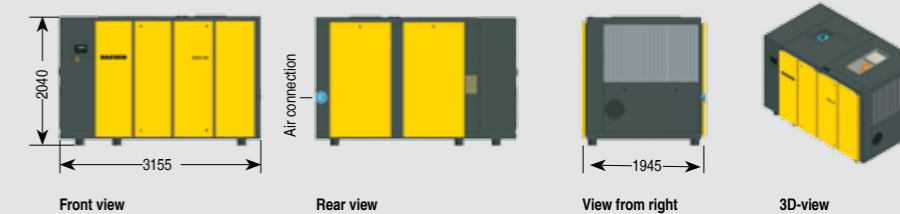

*) FAD in accordance with ISO 1217:2009, Annex C; **) Sound pressure level as per ISO 2151 and the basic standard ISO 9614-2, tolerance: ± 3 dB(A); ***) At high fan speed

Choose the required grade of treatment according to your field of application:

Air treatment using a refrigeration dryer (pressure dew point +3 °C)

Application examples: selection of treatment classes to ISO 8573-1

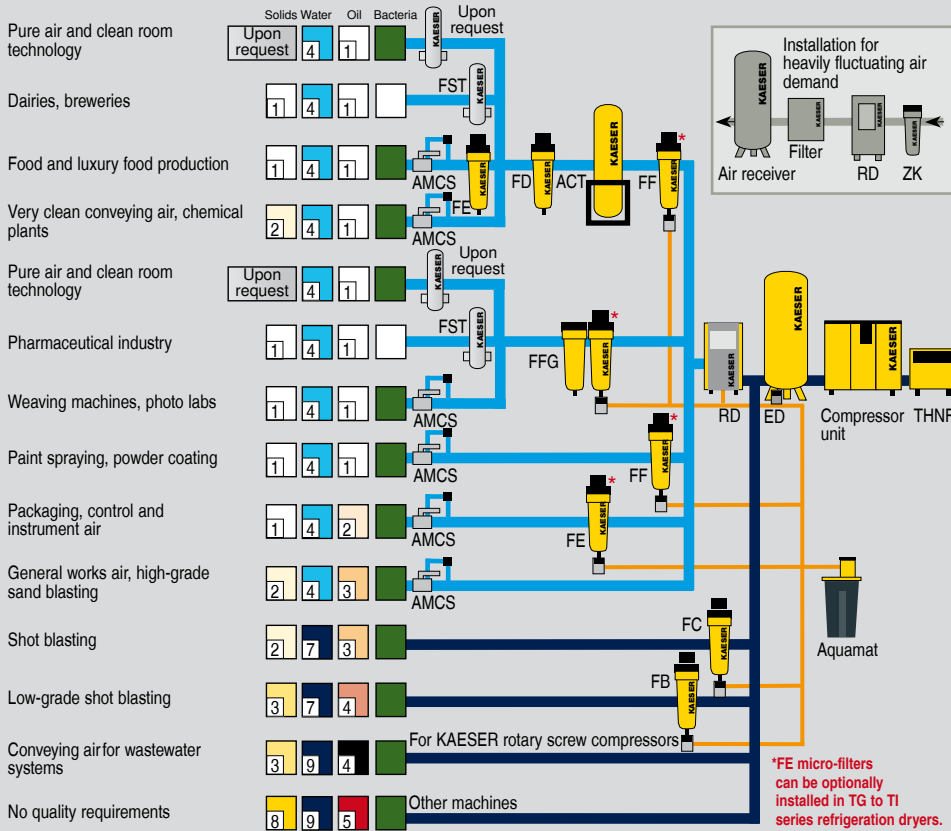

For air mains subject to sub-zero temperatures: Compressed air treatment with a desiccant dryer (down to -70 °C pressure dew point)

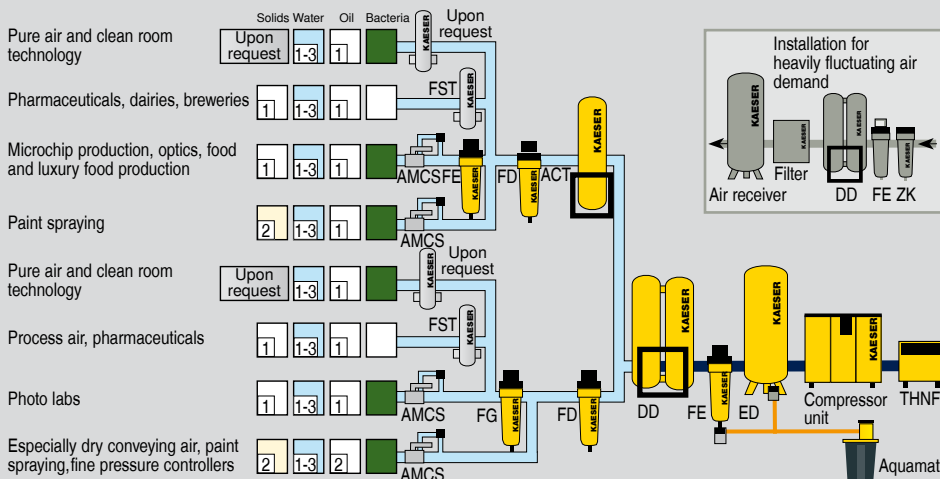

Explanation	
THNF	Bag filter
ZK	Centrifugal separator
ED	ECO DRAIN
FB / FC	Pre-filter
FD	Particulate filter
FE / FF	Microfilter
FG	Activated carbon filter
FFG	Activated carbon and microfilter combination
RD	Refrigeration dryer
DD	Desiccant dryer
ACT	ACT activated carbon adsorber
FST	Sterile filters
Aquamat	Aquamat
AMCS	Air-main charging system

Compressed air quality classes to ISO 8573-1(2010):

Solid particles / dust			
Class	Max. particle count per m ³ of a particle size with d [µm]*		
	0.1 ≤ d ≤ 0.5	0.5 ≤ d ≤ 1.0	1.0 ≤ d ≤ 5.0
0	e.g. Consult KAESER regarding pure air and cleanroom technology		
1	≤ 20,000	≤ 400	≤ 10
2	≤ 400,000	≤ 6,000	≤ 100
3	not defined	≤ 90,000	≤ 1,000
4	not defined	not defined	≤ 10,000
5	not defined	not defined	≤ 100,000
Particle concentration C _p [mg/m ³]*			
6	0 < C _p ≤ 5		
7	5 < C _p ≤ 10		
X	C _p > 10		

Water	
Class	Pressure dew point [°C]
0	e.g. Consult KAESER regarding pure air and cleanroom technology
1	≤ -70 °C
2	≤ -40 °C
3	≤ -20 °C
4	≤ +3 °C
5	≤ +7 °C
6	≤ +10 °C
Concentration of liquid water C _w [g/m ³]*	
7	C _w ≤ 0.5
8	0.5 < C _w ≤ 5
9	5 < C _w ≤ 10
X	C _w ≤ 10

Oil	
Class	Total oil concentration (fluid, aerosol + gaseous) [mg/m ³]*
0	e.g. Consult KAESER regarding pure air and cleanroom technology
1	≤ 0.01
2	≤ 0.1
3	≤ 1.0
4	≤ 5.0
X	> 5.0

* At reference conditions 20 °C, 1 bar(a), 0% humidity